

Corso di Calcolatori Elettronici I

Progetto di contatori sincroni

Roberto Canonico

Università degli Studi di Napoli Federico II

A.A. 2017-2018



Contatore modulo-16

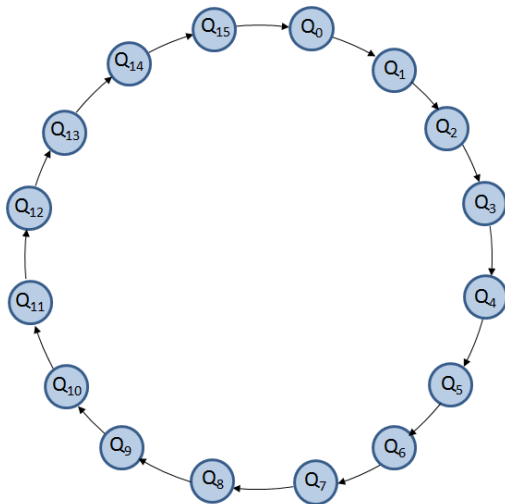

Contatore modulo-16 con FF JK



q_3	q_2	q_1	q_0	q'_3	q'_2	q'_1	q'_0	J_3	K_3	J_2	K_2	J_1	K_1	J_0	K_0
0	0	0	0	0	0	0	1	0	-	0	-	0	-	1	-
0	0	0	1	0	0	1	0	0	-	0	-	1	-	-	1
0	0	1	0	0	0	1	1	0	-	0	-	-	0	1	-
0	0	1	1	0	1	0	0	0	-	1	-	-	1	-	1
0	1	0	0	0	1	0	1	0	-	-	0	0	-	1	-
0	1	0	1	0	1	1	0	0	-	-	0	1	-	-	1
0	1	1	0	0	1	1	1	0	-	-	0	-	0	1	-
0	1	1	1	1	0	0	0	1	-	-	1	-	1	-	1
1	0	0	0	1	0	0	1	-	0	0	-	0	-	1	-
1	0	0	1	1	0	1	0	-	0	0	-	1	-	-	1
1	0	1	0	1	0	1	1	-	0	0	-	-	0	1	-
1	0	1	1	1	1	0	0	-	0	1	-	-	1	-	1
1	1	0	0	1	1	0	1	-	0	-	0	0	-	1	-
1	1	0	1	1	1	1	0	-	0	-	0	1	-	-	1
1	1	1	0	1	1	1	1	-	0	-	0	-	0	1	-
1	1	1	1	0	0	0	0	-	1	-	1	-	1	-	1



Contatore mod-16: posizionamento dei FF JK

J3

	q3q2	00	01	11	10
q1q0	00			-	-
	01			-	-
	11	1	-	-	-
	10			-	-

J2

	q3q2	00	01	11	10
q1q0	00		-	-	
	01		-	-	
	11	1	-	-	1
	10		-	-	

J1

	q3q2	00	01	11	10
q1q0	00				
	01	1	1	1	1
	11	-	-	-	-
	10	-	-	-	-

J0

	q3q2	00	01	11	10
q1q0	00	1	1	1	1
	01	-	-	-	-
	11	-	-	-	-
	10	1	1	1	1

K3

	q3q2	00	01	11	10
q1q0	00	-	-		
	01	-	-		
	11	-	-	1	
	10	-	-		

K2

	q3q2	00	01	11	10
q1q0	00	-			-
	01	-			-
	11	-	1	1	-
	10	-			-

K1

	q3q2	00	01	11	10
q1q0	00	-	-	-	-
	01	-	-	-	-
	11	1	1	1	1
	10				

K0

	q3q2	00	01	11	10
q1q0	00	-	-	-	-
	01	1	1	1	1
	11	1	1	1	1
	10	-	-	-	-

$$J_3 = K_3 = q_2 \cdot q_1 \cdot q_0 \quad J_2 = K_2 = q_1 \cdot q_0 \quad J_1 = K_1 = q_0 \quad J_0 = K_0 = 1$$

- Si osservi che risulta $J_i = K_i, \forall i$ pur non avendolo imposto come condizione

Contatore mod-16: circuito

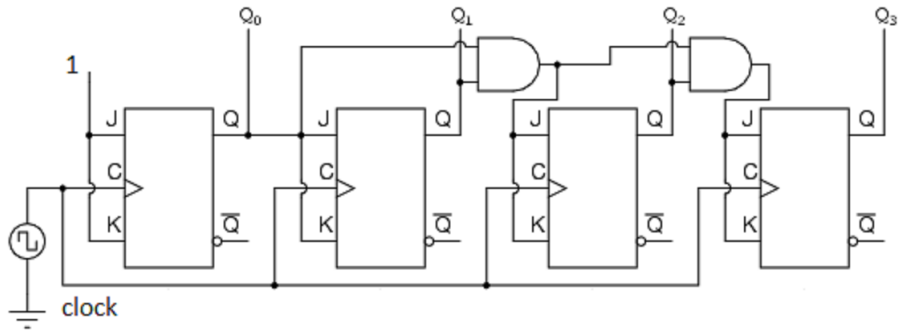



Contatore mod-16: diagramma di tempificazione

- Flip-flop positive edge-triggered (commutazione sul fronte di salita)

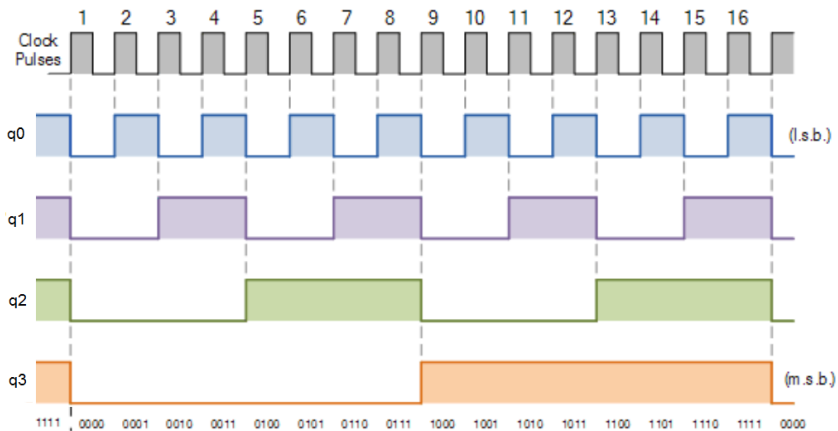

Contatore modulo-16 a decrescere

Contatore modulo-16 a decrescere: grafo degli stati

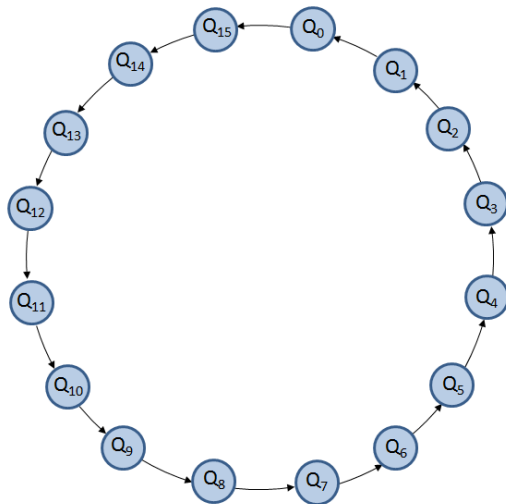

Contatore modulo-16 a decrescere con FF JK



q_3	q_2	q_1	q_0	q'_3	q'_2	q'_1	q'_0	J_3	K_3	J_2	K_2	J_1	K_1	J_0	K_0
0	0	0	0	1	1	1	1	1	-	1	-	1	-	1	-
0	0	0	1	0	0	0	0	0	-	0	-	0	-	-	1
0	0	1	0	0	0	0	1	0	-	0	-	-	1	1	-
0	0	1	1	0	0	1	0	0	-	0	-	-	0	-	1
0	1	0	0	0	0	1	1	0	-	-	1	1	-	1	-
0	1	0	1	0	1	0	0	0	-	-	0	0	-	-	1
0	1	1	0	0	1	0	1	0	-	-	0	-	1	1	-
0	1	1	1	0	1	1	0	0	-	-	0	-	0	-	1
1	0	0	0	0	1	1	1	-	1	1	-	1	-	1	-
1	0	0	1	1	0	0	0	-	0	0	-	0	-	-	1
1	0	1	0	1	0	0	1	-	0	0	-	-	1	1	-
1	0	1	1	1	0	1	0	-	0	0	-	-	0	-	1
1	1	0	0	1	0	1	1	-	0	-	1	1	-	1	-
1	1	0	1	1	1	0	0	-	0	-	0	0	-	-	1
1	1	1	0	1	1	0	1	-	0	-	0	-	1	1	-
1	1	1	1	1	1	1	0	-	0	-	0	-	0	-	1

Contatore mod-16 a decrescere: posizionamento dei FF



J3

q1q0 \ q3q2	00	01	11	10
00	1		-	-
01			-	-
11			-	-
10			-	-

J2

q1q0 \ q3q2	00	01	11	10
00	1	-	-	1
01		-	-	
11		-	-	
10		-	-	

J1

q1q0 \ q3q2	00	01	11	10
00	1	1	1	1
01				
11	-	-	-	-
10	-	-	-	-

J0

q1q0 \ q3q2	00	01	11	10
00	1	1	-	1
01	-	-	-	-
11	-	-	-	-
10	1	1	-	-

K3

q1q0 \ q3q2	00	01	11	10
00	-	-		1
01	-	-		
11	-	-		
10	-	-		

K2

q1q0 \ q3q2	00	01	11	10
00	-	1	1	-
01	-			-
11	-			-
10	-			-

K1

q1q0 \ q3q2	00	01	11	10
00	-	-	-	-
01	-	-	-	-
11				
10	1	1	1	1

K0

q1q0 \ q3q2	00	01	11	10
00	-	-	-	-
01	1	1	-	1
11	1	1	-	-
10	-	-	-	-

$$J_3 = K_3 = \overline{q_2} \cdot \overline{q_1} \cdot \overline{q_0}$$

$$J_2 = K_2 = \overline{q_1} \cdot \overline{q_0}$$

$$J_1 = K_1 = \overline{q_0}$$

$$J_0 = K_0 = 1$$

Contatore modulo-16 up/down



- Un ingresso up discrimina tra conteggio a crescere e a decrescere
- Il posizionamento dei flip-flop JK avviene secondo ...
 - le modalità determinate per il contatore a crescere se $up = 1$
 - le modalità determinate per il contatore a decrescere se $up = 0$

$$\begin{aligned}J_3 = K_3 &= q_2 \cdot q_1 \cdot q_0 \cdot up + \overline{q_2} \cdot \overline{q_1} \cdot \overline{q_0} \cdot \overline{up} \\J_2 = K_2 &= q_1 \cdot q_0 \cdot up + \overline{q_1} \cdot \overline{q_0} \cdot \overline{up} \\J_1 = K_1 &= q_0 \cdot up + \overline{q_0} \cdot \overline{up} \\J_0 = K_0 &= 1\end{aligned}$$

Contatore mod-16 up/down: circuito

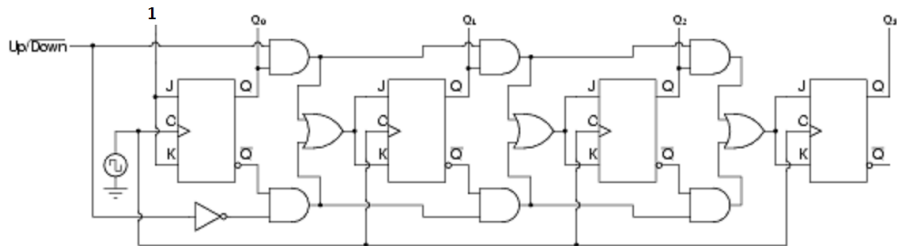

Contatore modulo-10

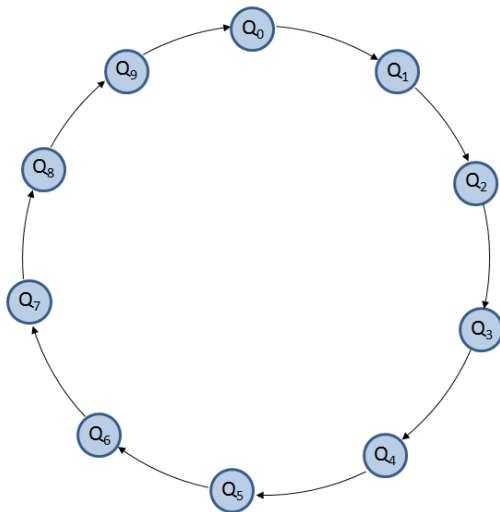

Contatore modulo-10 con FF JK



q_3	q_2	q_1	q_0	q'_3	q'_2	q'_1	q'_0	J_3	K_3	J_2	K_2	J_1	K_1	J_0	K_0
0	0	0	0	0	0	0	1	0	-	0	-	0	-	1	-
0	0	0	1	0	0	1	0	0	-	0	-	1	-	-	1
0	0	1	0	0	0	1	1	0	-	0	-	-	0	1	-
0	0	1	1	0	1	0	0	0	-	1	-	-	1	-	1
0	1	0	0	0	1	0	1	0	-	-	0	0	-	1	-
0	1	0	1	0	1	1	0	0	-	-	0	1	-	-	1
0	1	1	0	0	1	1	1	0	-	-	0	-	0	1	-
0	1	1	1	1	0	0	0	1	-	-	1	-	1	-	1
1	0	0	0	1	0	0	1	-	0	0	-	0	-	1	-
1	0	0	1	0	0	0	0	-	1	0	-	0	-	-	1
1	0	1	0	-	-	-	-	-	-	-	-	-	-	-	-
1	0	1	1	-	-	-	-	-	-	-	-	-	-	-	-
1	1	0	0	-	-	-	-	-	-	-	-	-	-	-	-
1	1	0	1	-	-	-	-	-	-	-	-	-	-	-	-
1	1	1	0	-	-	-	-	-	-	-	-	-	-	-	-
1	1	1	1	-	-	-	-	-	-	-	-	-	-	-	-



Contatore mod-10: posizionamento dei FF JK

J3

q1q0 \ q3q2	00	01	11	10
00			-	-
01			-	-
11		1	-	-
10			-	-

J2

q1q0 \ q3q2	00	01	11	10
00		-	-	
01		-	-	
11		1	-	-
10		-	-	-

J1

q1q0 \ q3q2	00	01	11	10
00			-	
01		1	1	-
11		-	-	-
10		-	-	-

J0

q1q0 \ q3q2	00	01	11	10
00	1	1	-	1
01	-	-	-	-
11	-	-	-	-
10	1	1	-	-

K3

q1q0 \ q3q2	00	01	11	10
00	-	-	-	
01	-	-	-	1
11	-	-	-	-
10	-	-	-	-

K2

q1q0 \ q3q2	00	01	11	10
00	-		-	-
01	-		-	-
11	-	1	-	-
10	-		-	-

K1

q1q0 \ q3q2	00	01	11	10
00	-	-	-	-
01	-	-	-	-
11	1	1	-	-
10			-	-

K0

q1q0 \ q3q2	00	01	11	10
00	-	-	-	-
01	1	1	-	1
11	1	1	-	-
10	-	-	-	-

$$J_3 = q_2 \cdot q_1 \cdot q_0$$

$$K_3 = q_0$$

$$J_2 = q_1 \cdot q_0$$

$$K_2 = q_1 \cdot q_0$$

$$J_1 = \overline{q_3} \cdot q_0$$

$$K_1 = q_0$$

$$J_0 = 1$$

$$K_0 = 1$$



- Flip-flop positive edge-triggered (commutazione sul fronte di salita)

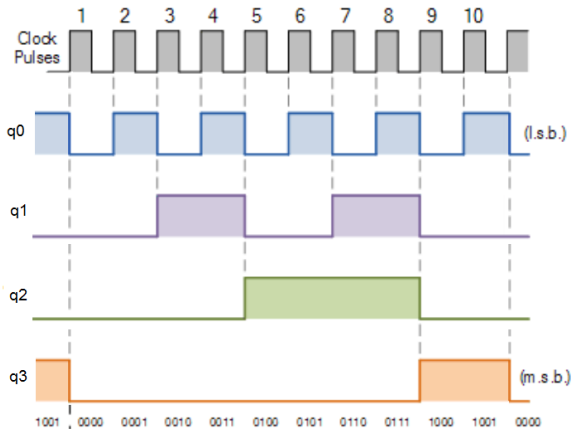



q_3	q_2	q_1	q_0	q'_3	q'_2	q'_1	q'_0	T_3	T_2	T_1	T_0
0	0	0	0	0	0	0	1	0	0	0	1
0	0	0	1	0	0	1	0	0	0	1	1
0	0	1	0	0	0	1	1	0	0	0	1
0	0	1	1	0	1	0	0	0	1	1	1
0	1	0	0	0	1	0	1	0	0	0	1
0	1	0	1	0	1	1	0	0	0	1	1
0	1	1	0	0	1	1	1	0	0	0	1
0	1	1	1	1	0	0	0	1	1	1	1
1	0	0	0	1	0	0	1	0	0	0	1
1	0	0	1	0	0	0	0	1	0	0	1
1	0	1	0	-	-	-	-	-	-	-	-
1	0	1	1	-	-	-	-	-	-	-	-
1	1	0	0	-	-	-	-	-	-	-	-
1	1	0	1	-	-	-	-	-	-	-	-
1	1	1	0	-	-	-	-	-	-	-	-
1	1	1	1	-	-	-	-	-	-	-	-

Contatore mod-10: posizionamento dei FF T



T3

q3q2	00	01	11	10
q1q0			-	
00			-	
01			-	1
11	1	-	-	
10			-	-

T2

q3q2	00	01	11	10
q1q0			-	
00			-	
01			-	
11	1	1	-	-
10			-	-

T1

q3q2	00	01	11	10
q1q0			-	
00			-	
01	1	1	-	
11	1	1	-	-
10			-	-

T0

q3q2	00	01	11	10
q1q0			-	
00	1	1	-	1
01	1	1	-	1
11	1	1	-	-
10	1	1	-	-

$$T_3 = q_3 \cdot q_0 + q_2 \cdot q_1 \cdot q_0$$

$$T_2 = q_1 \cdot q_0$$

$$T_1 = \overline{q_3} \cdot q_0$$

$$T_0 = 1$$

Contatore mod-10: circuito con FF JK usati come T

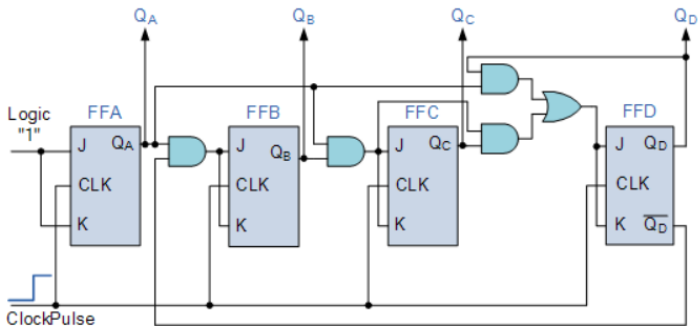

- Il circuito rispecchia il progetto fatto nella slide precedente con $Q_A = q_0$, $Q_B = q_1$, $Q_C = q_2$ e $Q_D = q_3$