

Corso di Laurea in Ingegneria Informatica



Corso di Reti di Calcolatori I

Roberto Canonico (roberto.canonico@unina.it)

Giorgio Ventre (giorgio.ventre@unina.it)

Virtual LAN: VLAN

**I lucidi presentati al corso sono uno strumento didattico che NON sostituisce i testi indicati nel programma del corso
I lucidi sono adattati dagli originali di J. Kurose e K. Ross e fanno riferimento al testo *Reti di calcolatori e Internet - Un approccio top-down* (4a ed.)**



Nota di Copyright

Questo insieme di trasparenze è stato ideato e realizzato dai ricercatori del Gruppo di Ricerca COMICS del Dipartimento di Informatica e Sistemistica dell'Università di Napoli Federico II. Esse possono essere impiegate liberamente per fini didattici esclusivamente senza fini di lucro, a meno di un esplicito consenso scritto degli Autori. Nell'uso dovranno essere esplicitamente riportati la fonte e gli Autori. Gli Autori non sono responsabili per eventuali imprecisioni contenute in tali trasparenze né per eventuali problemi, danni o malfunzionamenti derivanti dal loro uso o applicazione.

Autori:

Simon Pietro Romano, Antonio Pescapè, Stefano Avallone,
Marcello Esposito, Roberto Canonico, Giorgio Ventre



Partizionamento di una rete mediante router

- La rete della figura a dx è ottenuta collegando tre LAN distinte mediante un router
- Il traffico broadcast rimane confinato in ciascun piano
- Le comunicazioni tra piano avvengono mediante router

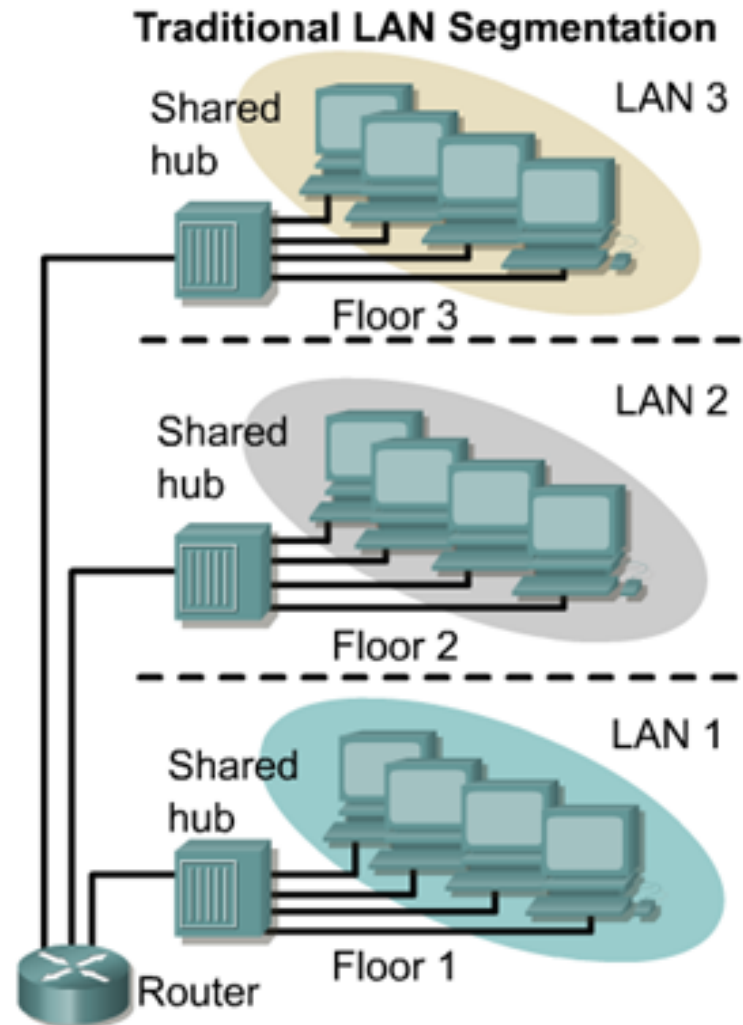



VLAN: necessità di partizionamento

- Spesso è necessario partizionare una rete in modalità che non seguono la collocazione fisica degli host
- Quando la rete è costituita da switch Ethernet che supportano le VLAN, questo è possibile proprio attraverso l'uso delle VLAN
- Una VLAN è un gruppo di porte di uno switch tra le quali è possibile una comunicazione diretta e l'inoltro di traffico broadcast (es ARP)
- La comunicazione tra VLAN diverse è possibile solo attraverso una funzione L3 (routing)

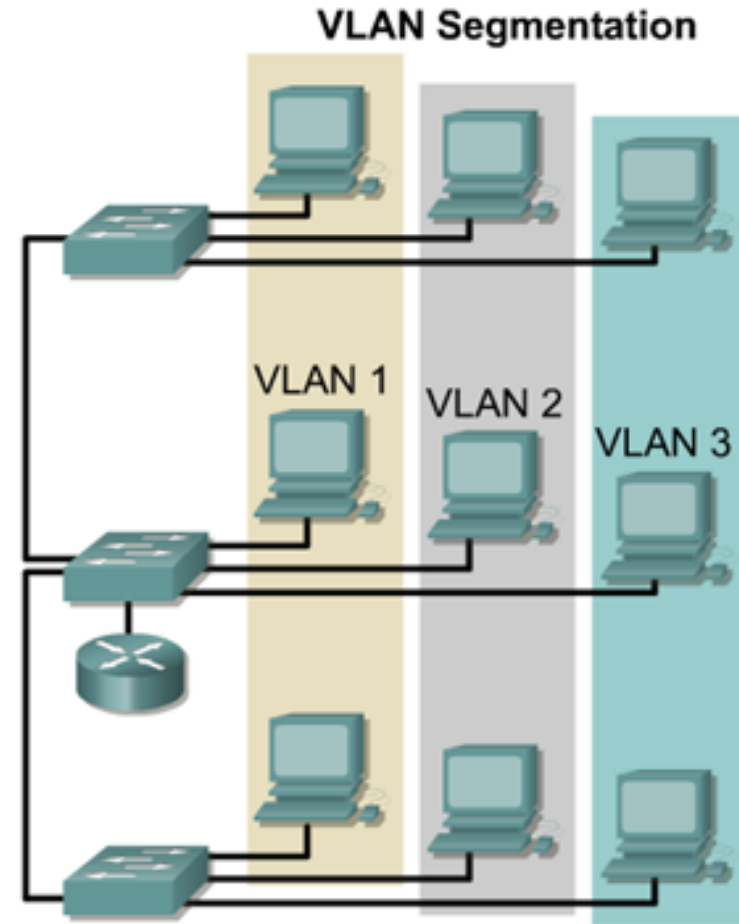



VLAN: come funzionano

- Attraverso l'uso di VLAN è possibile partizionare un'unica infrastruttura LAN creata attraverso l'interconnessione di switch Ethernet in reti "LAN virtuali" distinte ciascuna delle quali forma un dominio di trasmissione broadcast
- Non sono possibili comunicazioni dirette tra host di VLAN differenti: solo attraverso una funzione di livello L3 (routing)
- Tipicamente, una VLAN coincide con una sottorete IP



Broadcast domains with VLANs and routers

1) Without VLANs

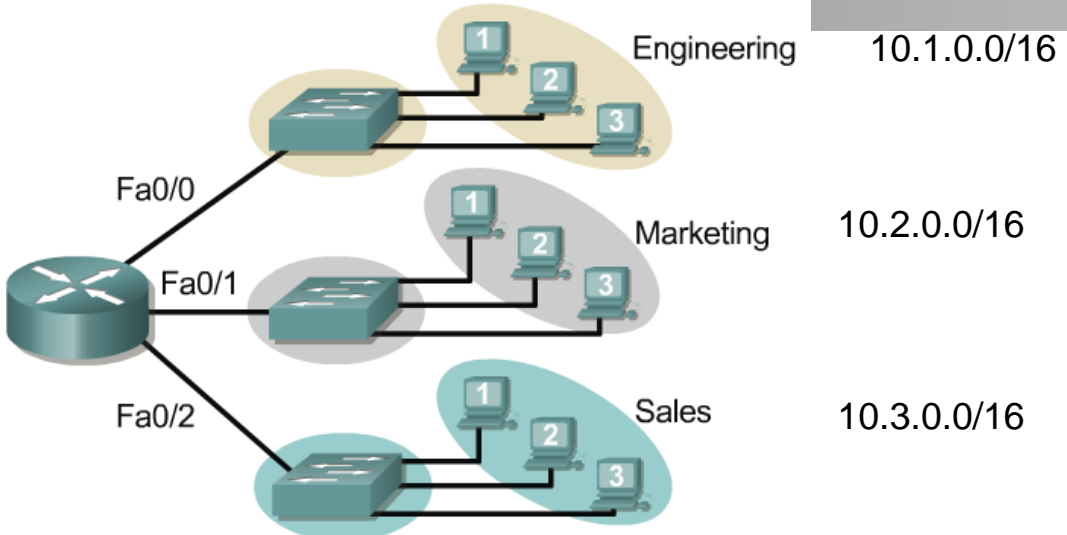

1) **Without VLANs**, each group is on a different IP network and on a different switch.

2) **Using VLANs**: Switch is configured with the ports on the appropriate VLAN. Still, each group on a different IP network; however, They are all on the same switch.

• What are the broadcast domains in each?

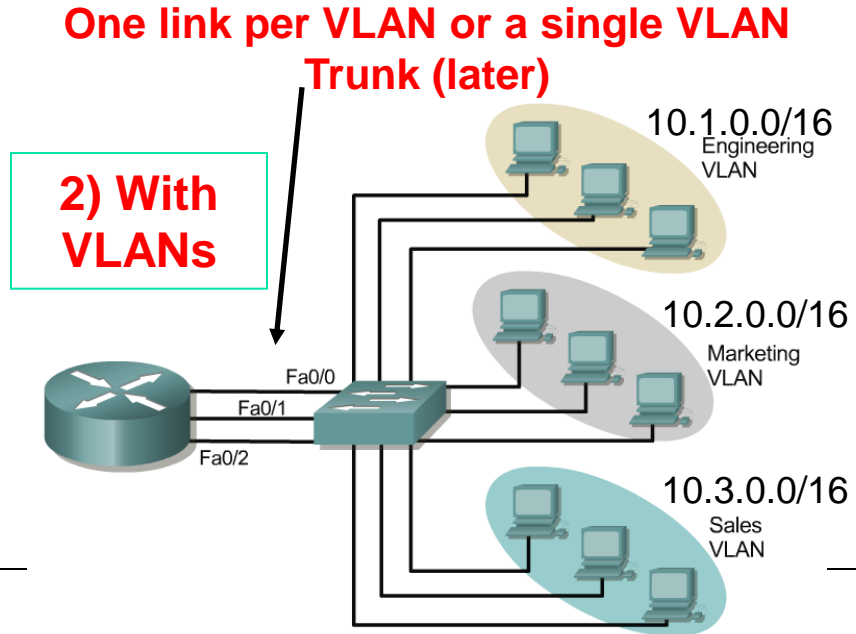

2) With VLANs



VLAN Types

Approaches Can Vary Performance

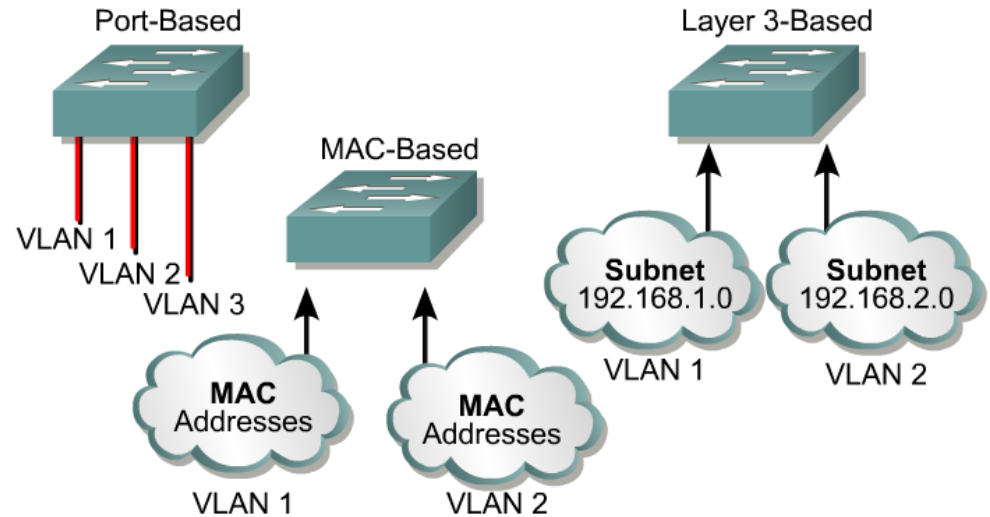

VLAN Types	Description
Port-based	<ul style="list-style-type: none">• Most common configuration method.• Ports assigned individually, in groups, in rows, or across 2 or more switches.• Simple to use.• Often implemented where Dynamic Host Control Protocol (DHCP) is used to assign IP addresses to network hosts.
MAC address	<ul style="list-style-type: none">• Rarely implemented today.• Each address must be entered into the switch and configured individually.• Users find it useful.• Difficult to administer, troubleshoot and manage.
Protocol Based	<ul style="list-style-type: none">• Configured like MAC addresses, but instead uses a logical or IP address.• No longer common because of DHCP.

Without VLANs – No Broadcast Control

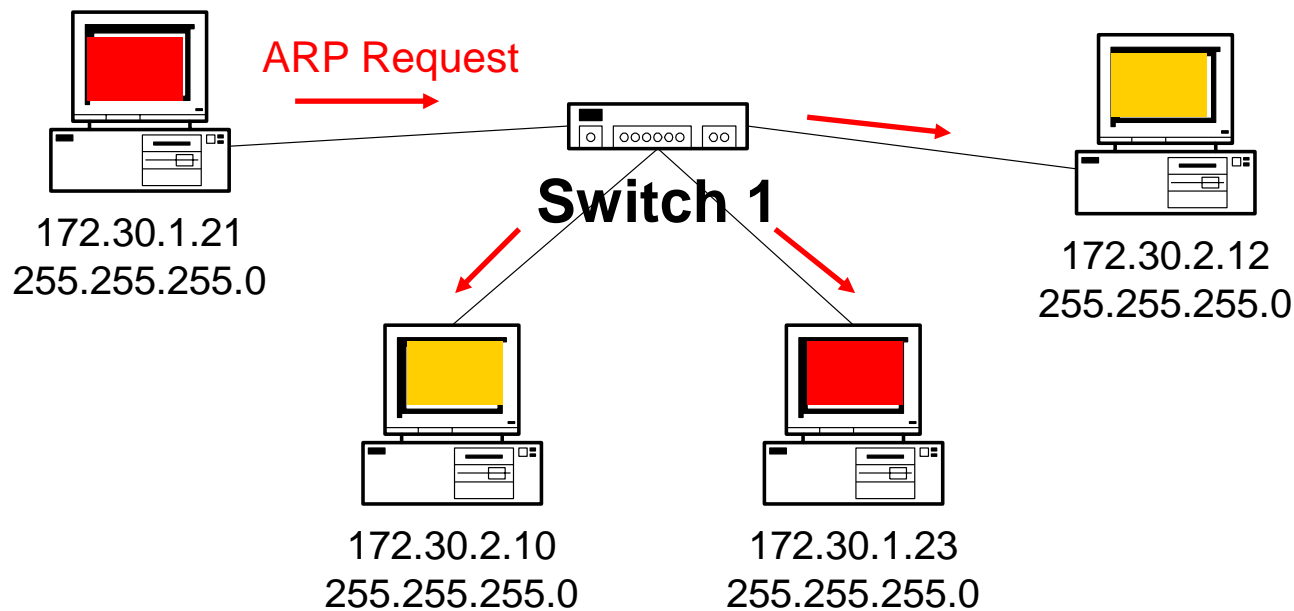

No VLANs

- Same as a single VLAN
- Two Subnets

- Without VLANs, the ARP Request would be seen by all hosts
- Consuming unnecessary network bandwidth and host processing cycles

With VLANs – Broadcast Control



Switch Port: VLAN ID

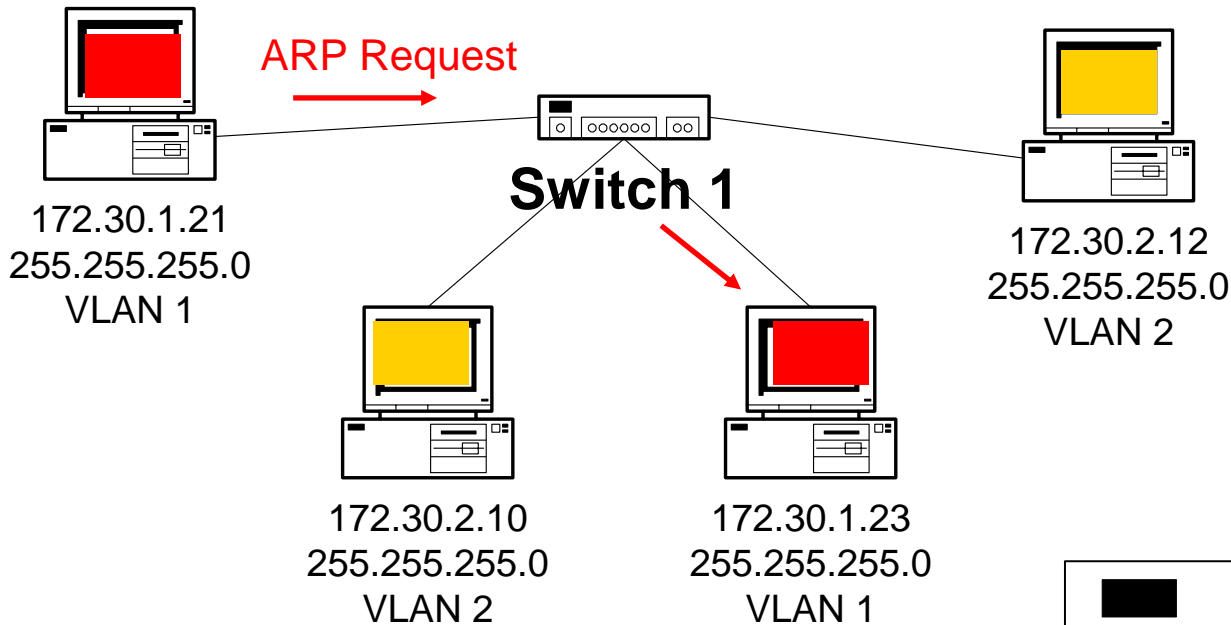

Two VLANs

- Two Subnets

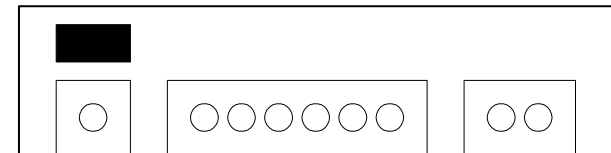

1	2	3	4	5	6	.	Port
1	2	1	2	2	1	.	VLAN



VLAN operation

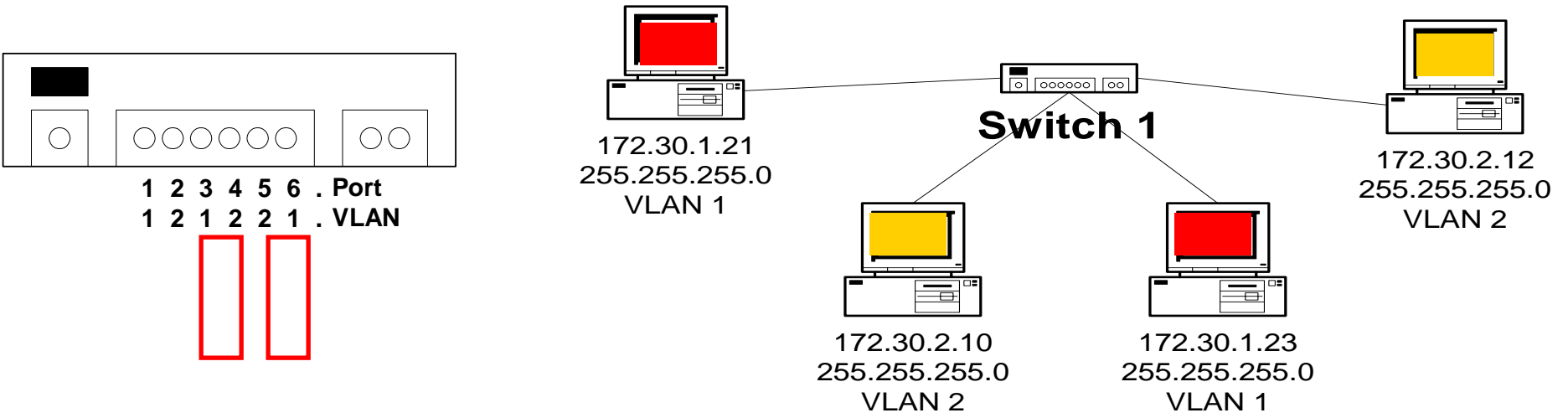

Important notes on VLANs:

- VLANs are assigned on the switch port
There is no “VLAN” assignment done on the host (usually)
- In order for a host to be a part of that VLAN, it must be assigned an IP address that belongs to the proper subnet. Remember: VLAN = Subnet
- Assigning a host to the correct VLAN is a 2-step process:
 1. Connect the host to the correct port on the switch
 2. Assign to the host the correct IP address depending on the VLAN membership

Two VLANs

- Two Subnets



VLAN operation

Configuring VLANs	Description
Statically	<p>Network administrators configure port-by-port.</p> <p>Each Port is associated with a specific VLAN.</p> <p>The network administrator is responsible for keying in the mappings between the ports and VLANs.</p>
Dynamically	<p>The ports are able to dynamically work out their VLAN configuration.</p> <p>Uses a software database of MAC address to VLAN mappings (which the network administrator must set up first).</p>

- Each switch port can be assigned to a different VLAN
- Ports assigned to the same VLAN share broadcasts
- Ports that do not belong to that VLAN do not share these broadcasts



VLAN operation

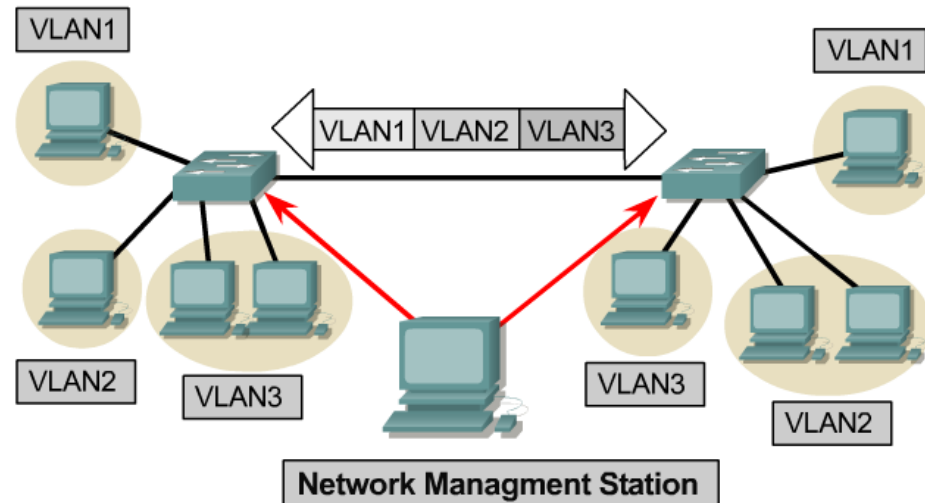

- **Static membership VLANs are called port-based VLANs**
- As a device enters the network, it automatically assumes the VLAN membership of the port to which it is attached
- The **default VLAN** for every port in the switch is the management VLAN (VLAN1) and **may not be deleted**
- All other ports on the switch may be reassigned to alternate VLANs



VLAN operation

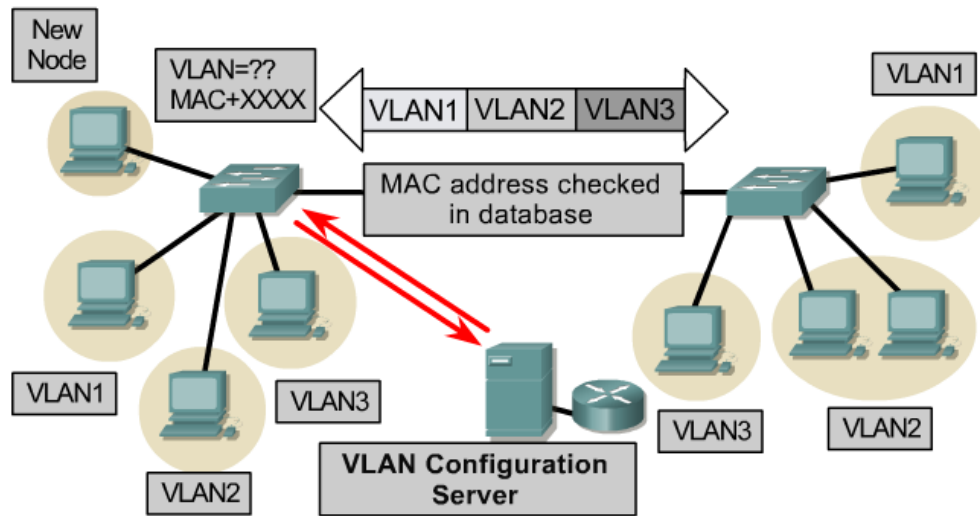

- Dynamic membership VLANs are created through network management software
 - Not as common as static VLANs
- Dynamic VLANs allow for membership based on the MAC address of the device connected to the switch port
- As a device enters the network, it queries a database within the switch for a VLAN membership



VLAN operation

- ◆ In port-based or port-centric VLAN membership, the port is assigned to a specific VLAN membership independent of the user or system attached to the port.

- ◆ All users of the same port must be in the same VLAN

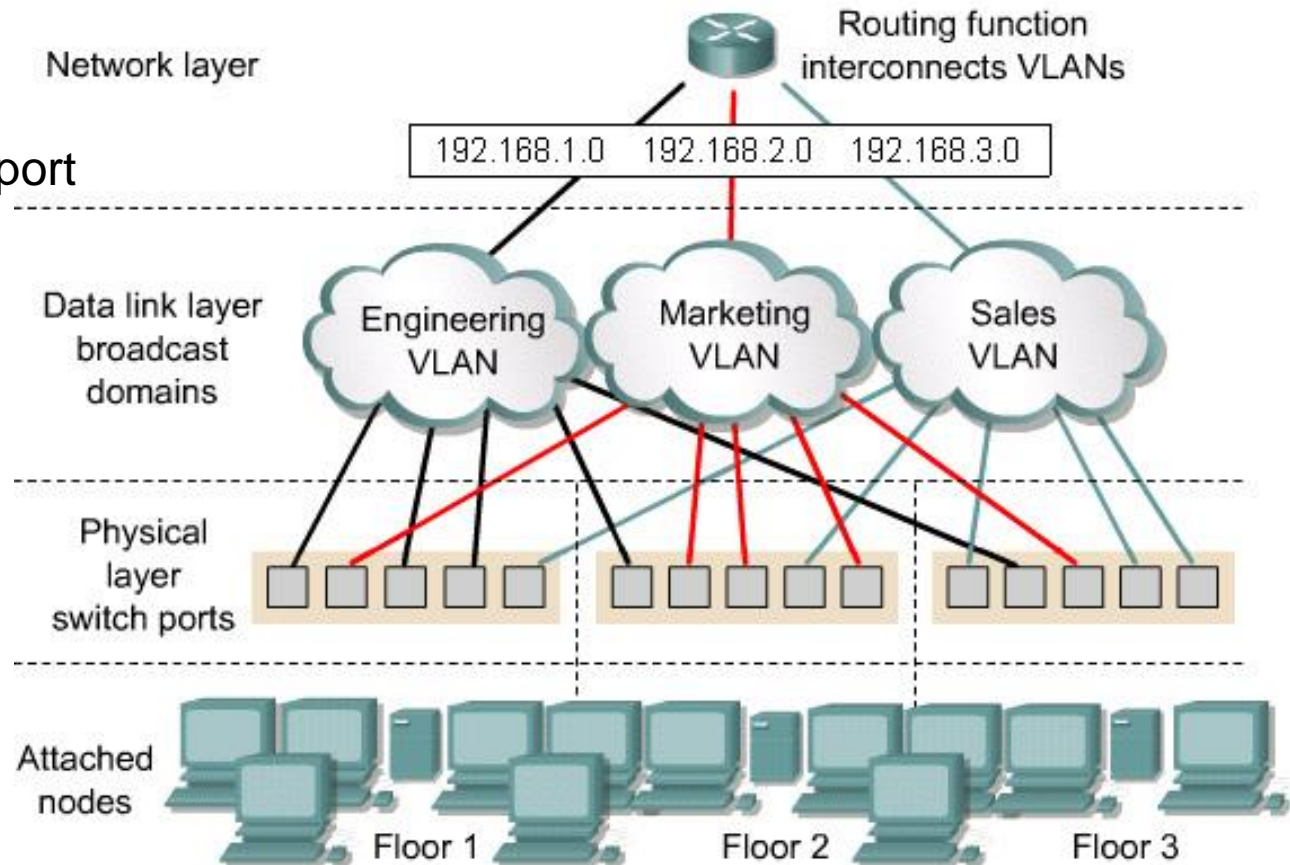



Membership by Port

Maximizes Forwarding Performance

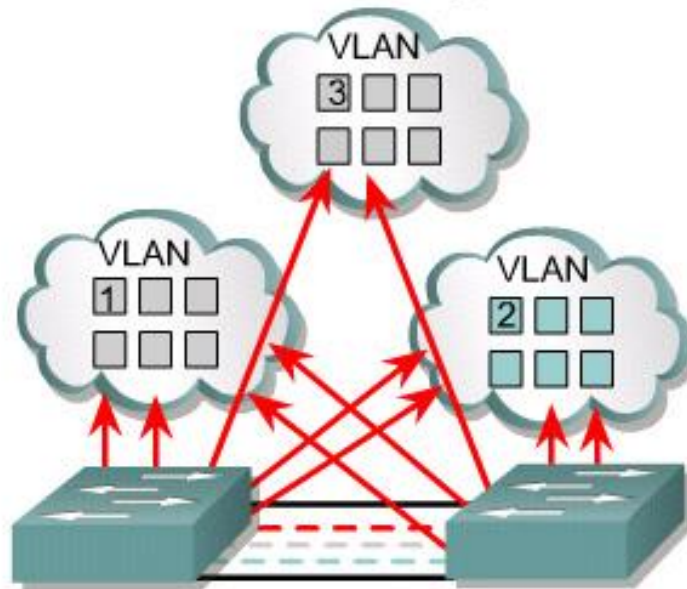

- User assigned by port association
- Requires no lookup if done in ASICs
- Easily administered via GUIs
- Maximizes security between VLANs
- Packets do not "leak" into other domains
- Easily controlled across network

Membership by MAC-Addresses



Requires Filtering, Impacts Performance

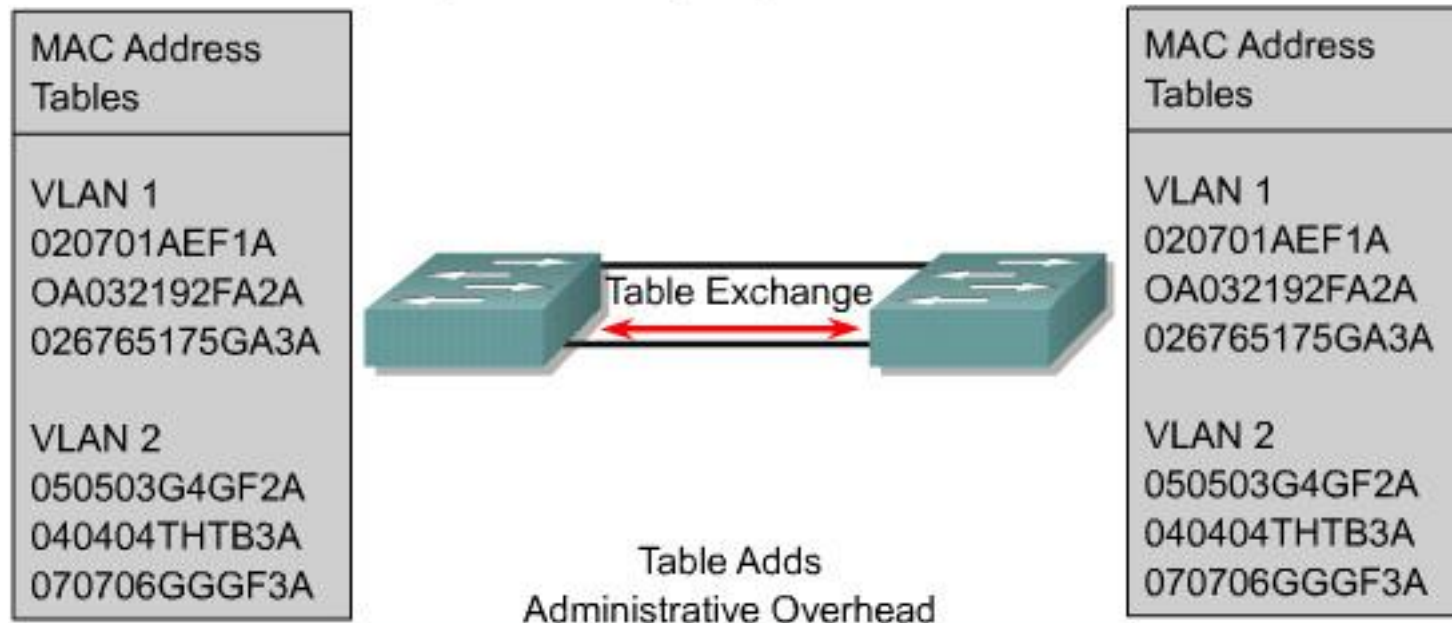

- User assigned based on MAC addresses
- Offers flexibility, yet adds overhead
- Impacts performance, scalability, and administration
- Offers similar process for higher layers



Comunicazione con VLAN

- Nella configurazione di VLAN rappresentata in figura, Gianni può inviare frame soltanto a Giulia

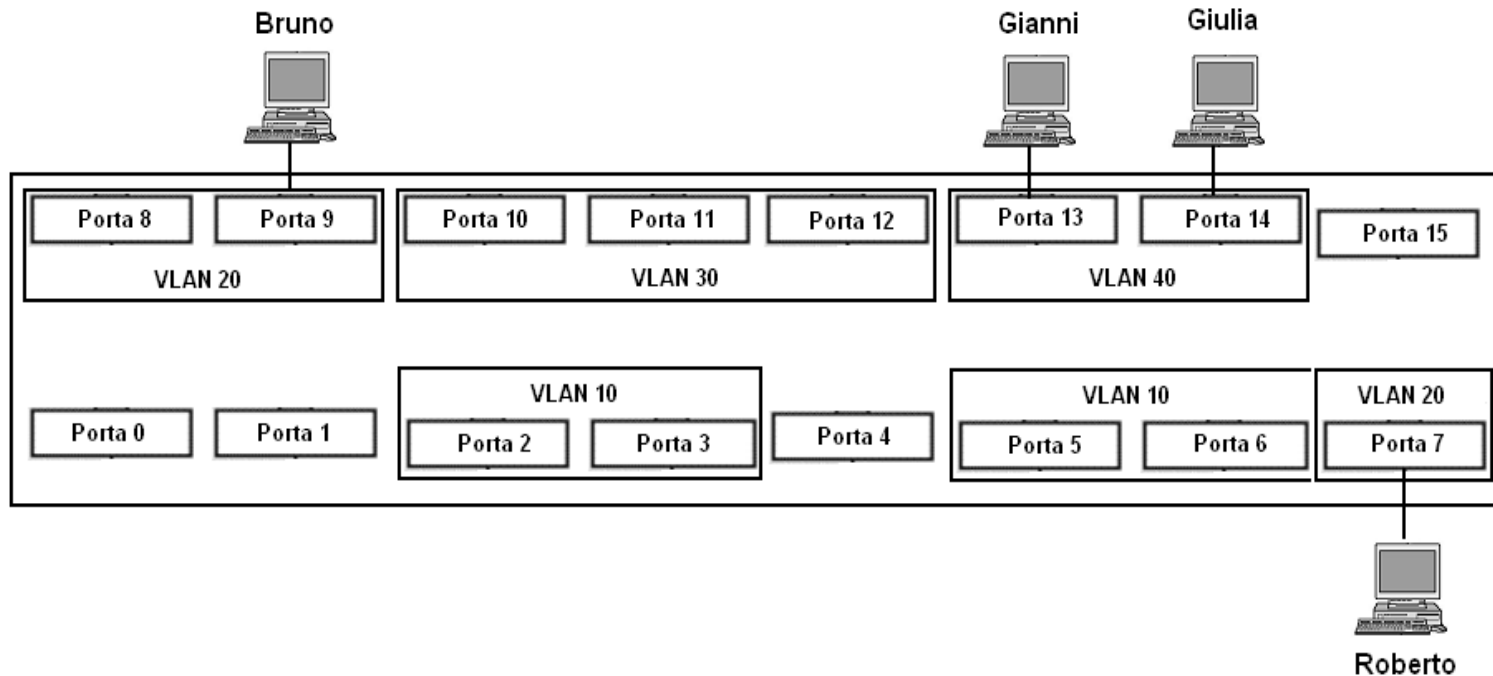



Comunicazione tra VLAN diverse

- Per fare comunicare VLAN diverse occorre creare un ponte attraverso un dispositivo apposito
 - bridge se opera a livello Ethernet (L2)
 - router se opera a livello rete (L3)

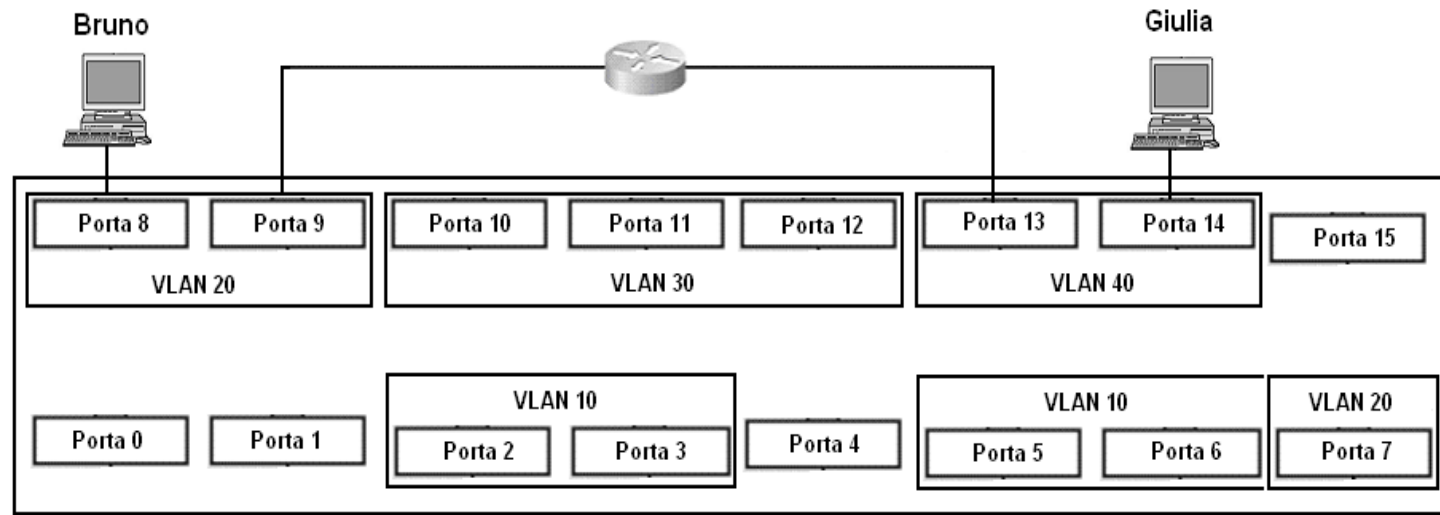

Switch/router



- Molti produttori offrono dispositivi in grado di svolgere contemporaneamente le funzioni di switch a livello Ethernet e di router a livello 3
- Questi dispositivi creano la connessione tra VLAN a livello 3

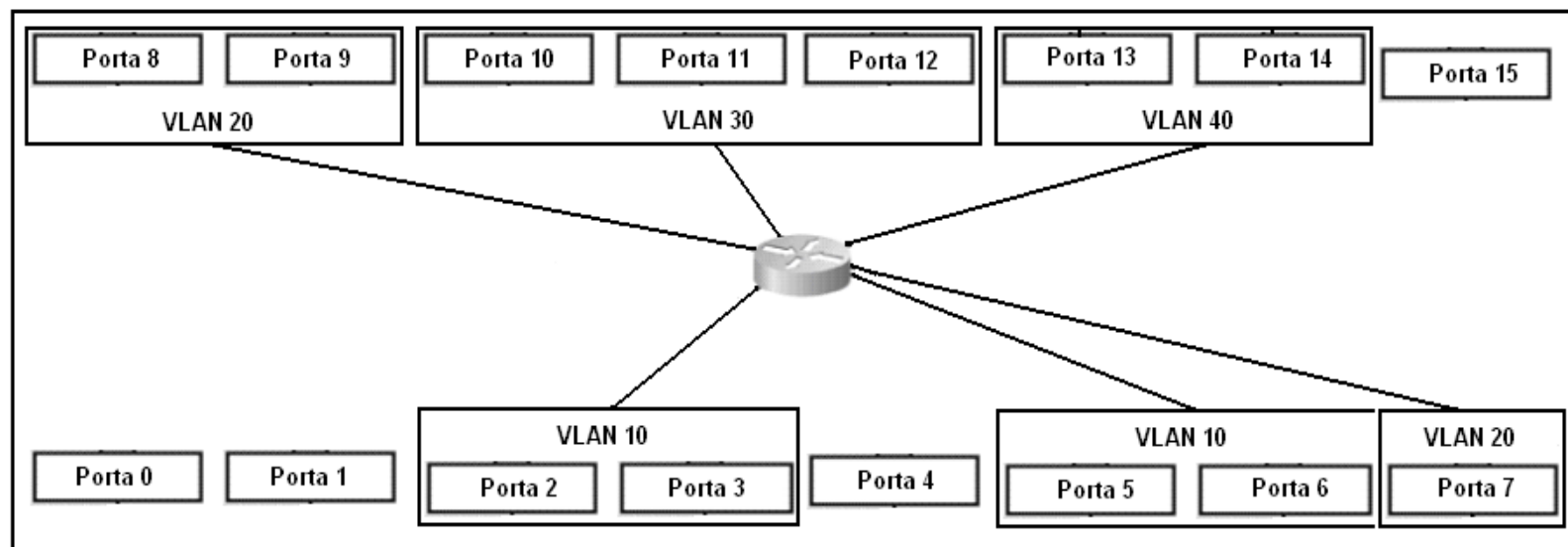



Connessione a livelli superiori (1)

- In linea di principio, si potrebbe ottenere lo stesso risultato collegando le interfacce di un router a tutte le coppie di VLAN

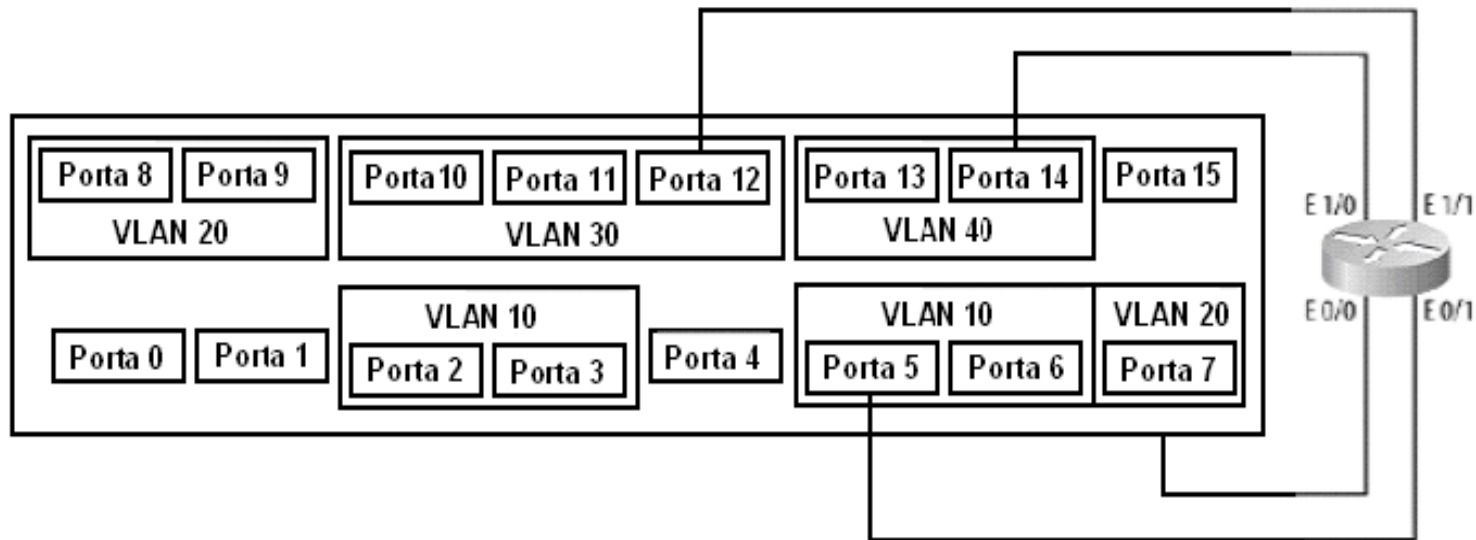



VLAN Trunking (1)

- La presenza delle VLAN crea un problema nella connessione tra due o più switch
 - Se collego la porta di uno switch a una porta di un altro switch, la connessione riguarderà solo le VLAN che comprendono le due porte utilizzate
 - Occorrerebbero quindi tanti collegamenti quante sono le VLAN da collegare

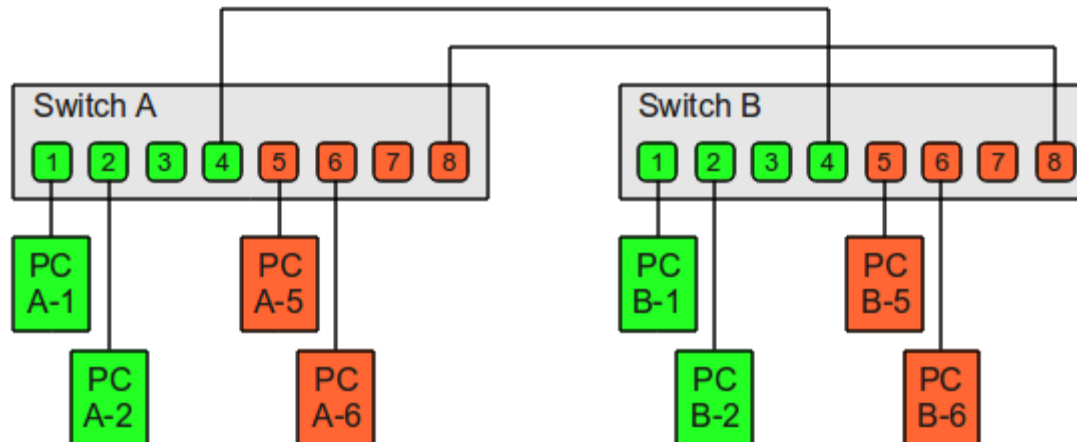



VLAN trunking (2)

- Il trunking abilita la connessione tra le VLAN di switch diversi
 - Perché lo switch di destinazione sappia a quale VLAN inoltrare i frame in arrivo su una porta di trunking, occorre *taggare* (contrassegnare) i frame con l'identificativo della VLAN di destinazione
 - Questo non è previsto dal protocollo Ethernet originale

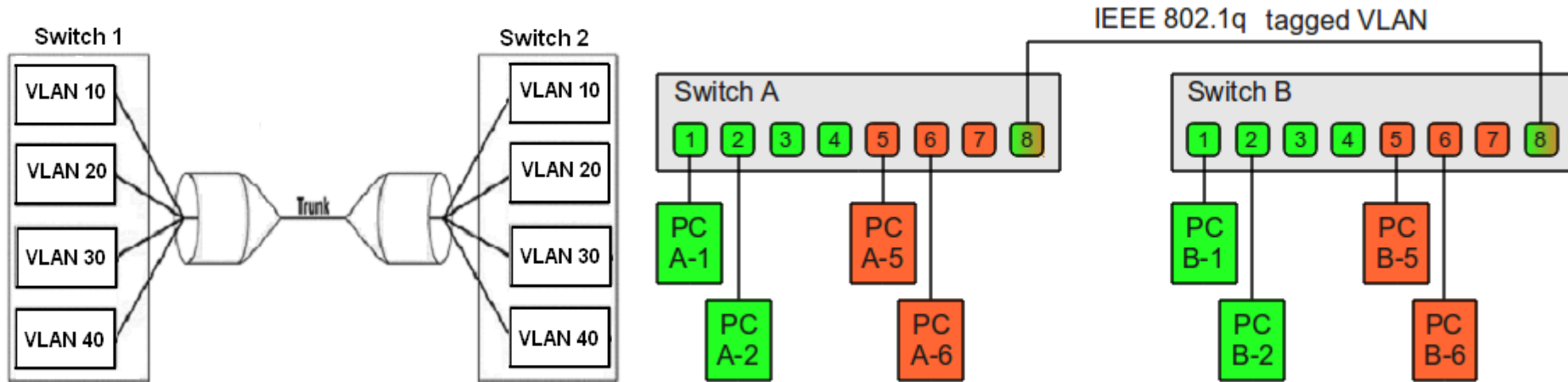



VLAN Tagging

- **VLAN Tagging is used when a link needs to carry traffic for more than one VLAN**
 - **Trunk link:** As packets are received by the switch from any attached end-station device, a unique packet identifier is added within each header.
- **This header information designates the VLAN membership of each packet**
- The packet is then forwarded to the appropriate switches or routers based on the VLAN identifier and MAC address
- Upon reaching the destination node (Switch) the VLAN ID is removed from the packet by the adjacent switch and forwarded to the attached device
- Packet tagging provides a mechanism for controlling the flow of broadcasts and applications while not interfering with the network and applications
- This is known as a trunk link or VLAN trunking



VLAN Tagging

No VLAN Tagging

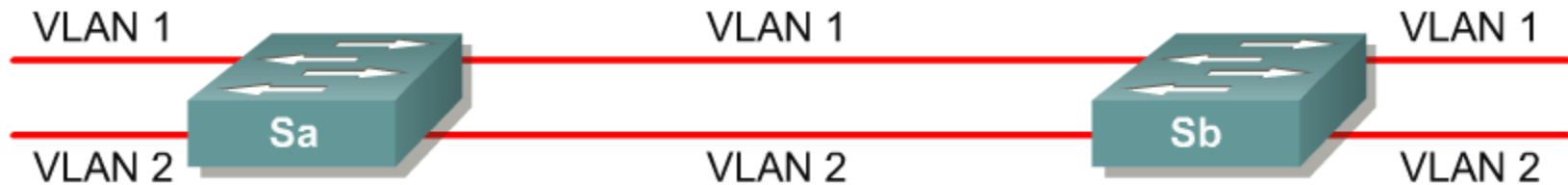

VLAN Tagging

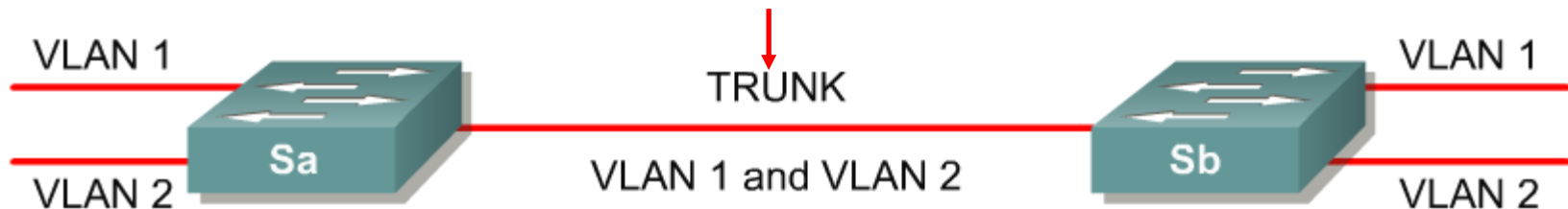

- VLAN Tagging is used when a single link needs to carry traffic for more than one VLAN



Protocolli di trunking (1)

• Protocolli a incapsulamento

- Viene aggiunto uno header al frame Ethernet per indicare la VLAN di destinazione
- Es. Cisco Inter-Switch Link (ISL)

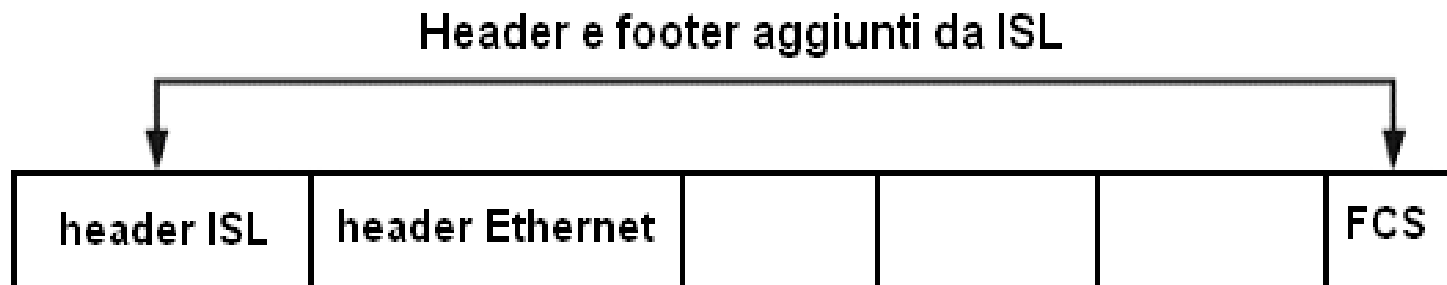



Protocolli di trunking (2)

- **Protocolli a piggyback (IEEE 802.1Q)**
 - L'identificativo della VLAN (12 bit) è parte di un campo da 4 byte inserito nel frame Ethernet tra i campi indirizzo sorgente e tipo
 - Occorre ricalcolare il CRC all'ingresso e all'uscita dal trunk

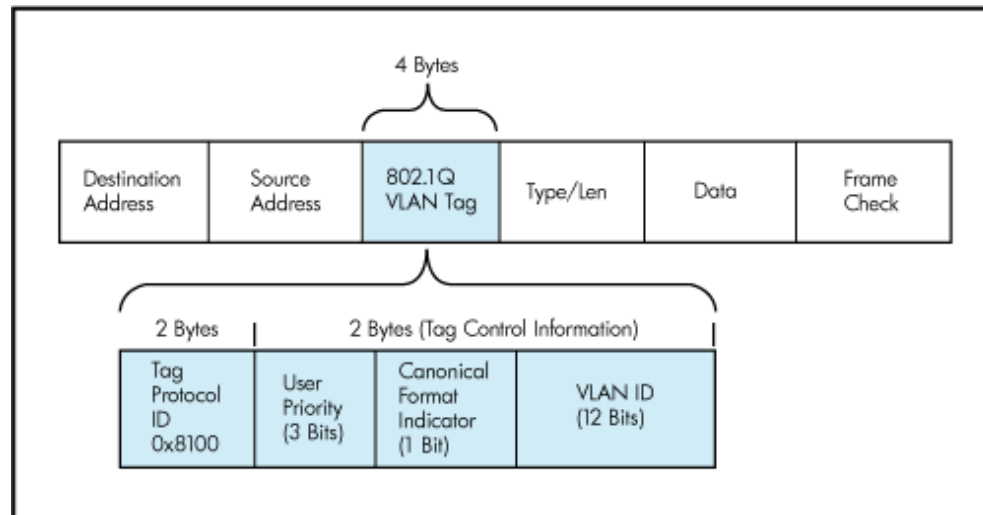



Router on a stick

Collegamento tra VLAN distinte mediante un router collegato ad uno switch mediante un collegamento in trunk mode

Soluzione più economica rispetto a quella basata su un collegamento per ciascuna VLAN

